

AP12 - Encapsulated Industrial Control Transformers

Series AP12 Industrial Control Transformers are designed to comply with industrial and automotive specifications that require the control transformer to be mounted in a separate enclosure, remote from the main control panel. Series AP12 control transformers eliminate the need to purchase a separate enclosure, as these units are encapsulated within a NEMA 12 enclosure suitable for remote mounting.

External or remote mounting of the Series AP12 conserves critical panel mounting space and reduces internal control cabinet temperatures, which can be critical to the reliable operation of many solid state, logic, and thermal control devices.

Features



- All copper windings.
- NEMA 12 enclosure and encapsulated core

and coil construction.

- **180°C Insulation System and 55°C Temperature Rise** for long service in high ambient environments.
- **50/60 Hertz.**
- **Capacity range from 1 kVA to 10 kVA.**
- Available primary voltages include 208, 240, and 380, 480, 575, 600. Secondary voltage is 120 volts.
- Primary and secondary leads are equipped with ring terminals for convenient connections.
- **Regulation characteristics** equal or exceed the highest industry standards.
- **Electrostatic shield** available as an extra cost option.
- Consult factory for desired voltage combinations and kVA sizes not listed.

General Information											
Pri. Volts	240 X 480 230 X 460 220 X 440	380 / 575	208	600 575 550	Dimensions (Inches)						Weight (lbs)
Sec. Volts	120 115 110	120	120	120 115 110	Height A	Width B	Depth C	Depth D	Mounting		
kVA Cap.	Catalog Number	Catalog Number	Catalog Number	Catalog Number					EE	FF	
1.0	AP12-351	AP12-352	AP12-353	AP12-354	10.50	10.00	6.62	6.12	4.00	8.50	50
1.5	AP12-401	AP12-402	AP12-403	AP12-404	12.00	10.81	7.19	6.69	6.00	9.13	68
2.0	AP12-451	AP12-452	AP12-453	AP12-454	14.00	14.00	9.25	8.75	8.00	12.00	97
3.0	AP12-501	AP12-502	AP12-503	AP12-504	14.00	14.00	9.25	8.75	8.00	12.00	120
5.0	AP12-551	AP12-552	AP12-553	AP12-554	14.00	14.38	10.00	9.50	8.00	12.38	149
7.5	AP12-601	AP12-602	AP12-603	AP12-604	15.00	18.00	12.50	12.00	8.00	16.00	198
10.0	AP12-651	AP12-652	AP12-653	AP12-654	15.00	18.00	12.50	12.00	8.00	16.00	225

PRIMARY 240 x 480

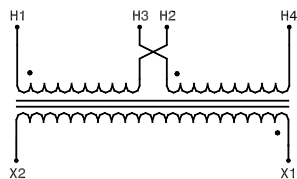

PRIMARY 600 or 208

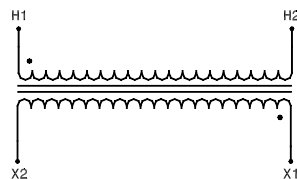

PRIMARY 380 / 575

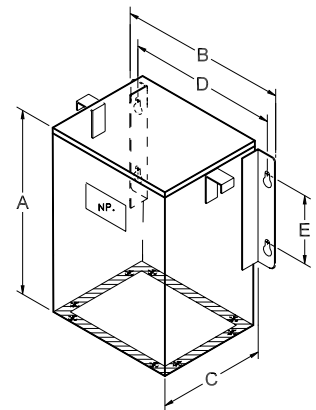
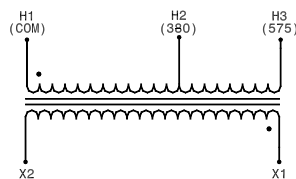

Dimensions & weights may change. Consult factory for certified drawings.

Series AP12
Wall Mount - Encapsulated - NEMA 12

Series FP12-Encapsulated Industrial Control Transformers

Series FP12 Industrial Control Transformers are similar to the AP12 Series with two important differences. The FP12 Series is 115°C rise (versus 55°C) and they are manufactured with an electrostatic shield between primary and secondary.

They are designed to comply with industrial and automotive specifications that require the control transformer to be mounted in a separate enclosure, remote from the main control panel.

External or remote mounting of the Series FP12 conserves critical panel mounting space and reduces internal control cabinet temperatures, which can be critical to the reliable operation of many solid state, logic, and thermal control devices.

and coil construction.

- **180°C Insulation System and 115°C Temperature Rise** for long service in high ambient environments.
- **Electrostatic Shield.**
- **60 Hz except 380/575-120 which is 50/60 Hz.**
- **50/60 Hz unit weights are approximately 20% higher than those shown.**
- **Primary and secondary leads** are equipped with ring terminals for convenient connections.
- **Regulation characteristics** equal or exceed the highest industry standards.
- Consult factory for desired voltage combinations and kVA sizes not listed.

Features



- **All copper windings.**
- **NEMA 12 enclosure** and encapsulated core

General Information										
Pri. Volts	240 X 480 230 X 460 220 X 440	380 / 575	208	600 575 550	Dimensions (inches)					Weight (lbs)
Sec. Volts	120 115 110	120	120	120 115 110	Height A	Width B	Depth C	Mounting		
kVA Cap.	Catalog Number	Catalog Number	Catalog Number	Catalog Number				D	E	
1.0	FP12-351	FP12-352	FP12-353	FP12-354	10.50	10.00	6.62	6.12	4.00	29
1.5	FP12-401	FP12-402	FP12-403	FP12-404	10.50	10.00	6.62	6.12	4.00	38
2.0	FP12-451	FP12-452	FP12-453	FP12-454	12.00	10.81	7.19	6.69	6.00	45
3.0	FP12-501	FP12-502	FP12-503	FP12-504	12.00	10.81	7.19	6.69	6.00	78
5.0	FP12-551	FP12-552	FP12-553	FP12-554	14.00	14.00	9.25	8.75	8.00	97
7.5	FP12-601	FP12-602	FP12-603	FP12-604	14.00	14.38	10.00	9.50	8.00	151
10.0	FP12-651	FP12-652	FP12-653	FP12-654	14.00	14.38	10.00	9.50	8.00	164

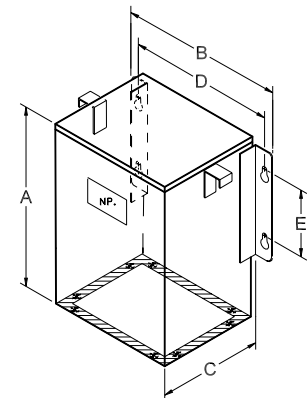
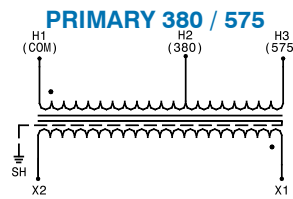
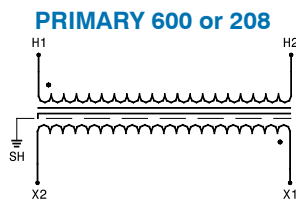
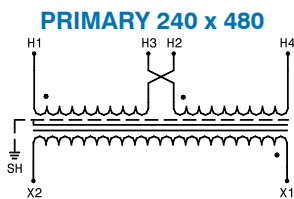

Dimensions & weights may change. Consult factory for certified drawings.

Series FP12
Wall Mount - Encapsulated - NEMA 12